



better together

50Hz

0 series

DGO
DRO

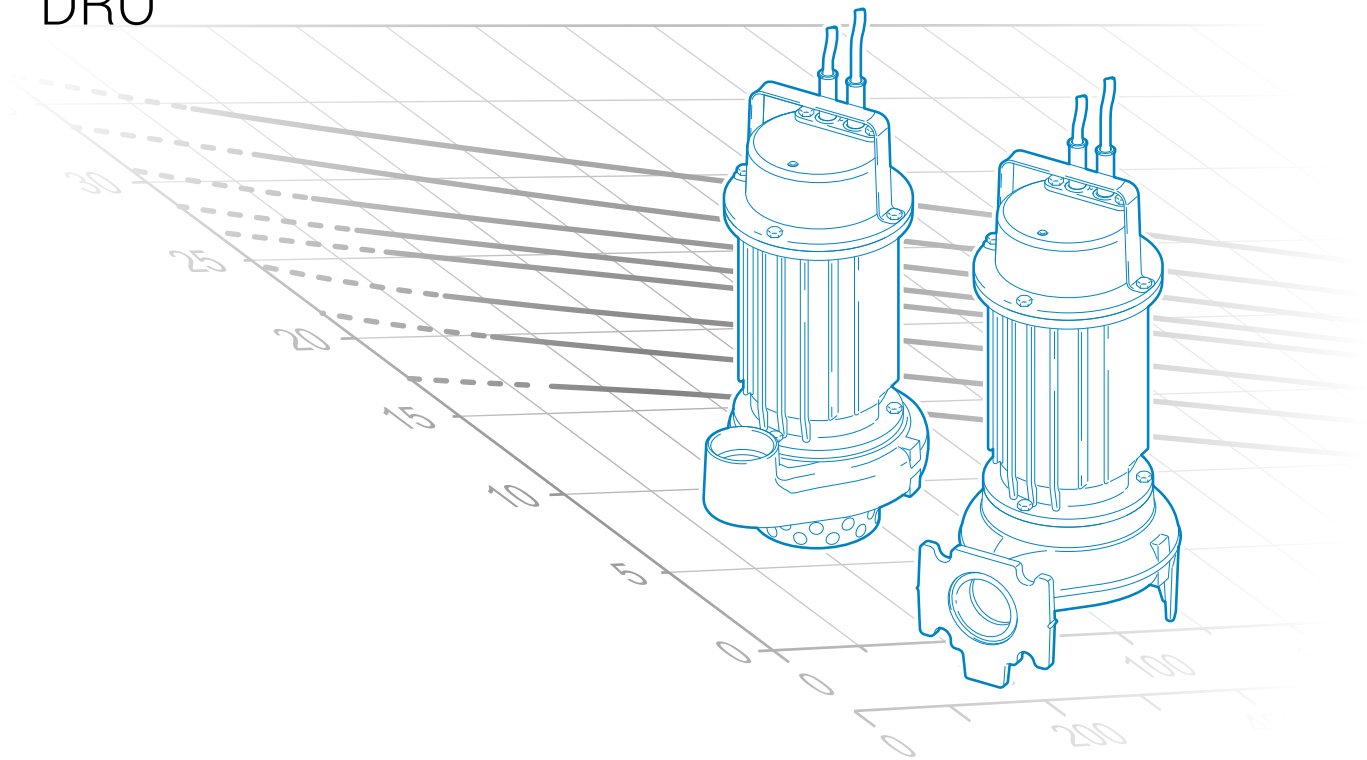

D A T A B O O K L E T

zenit.com

EN



better together

0 Series

DGO

DRO



D A T A B O O K L E T

O Series

General characteristics



- AISI 304 stainless steel lifting and carrying handle
- Constructed in GJL-250 cast iron
- One mechanical seal in silicon carbide (SiC) and one mechanical seal in alumina graphite (AL)
- Oil bath motor with thermal protections
- Capacitor and overload protection in external cabinet.
- Threaded, flanged discharge for the maximum ease of installation
- Wide free passage allowing the expulsion of solids and preventing fouling of the impeller (DGO)
- Intake strainer in stainless steel (DRO)

Hydraulic families



DG (Draga)

page 7

- Set-back vortex impeller
- Suitable for heavy-duty applications with soiled biological wastewaters, sewage, rainwater and seepage



DR (Dreno)

page 20

- Multi-channel open impeller
- Can be used with clear or slightly soiled wastewaters containing small solids, strained water, rainwater, seepage and water pumped from underground. Suitable for heavy-duty domestic and professional applications

Operating ranges

DGO

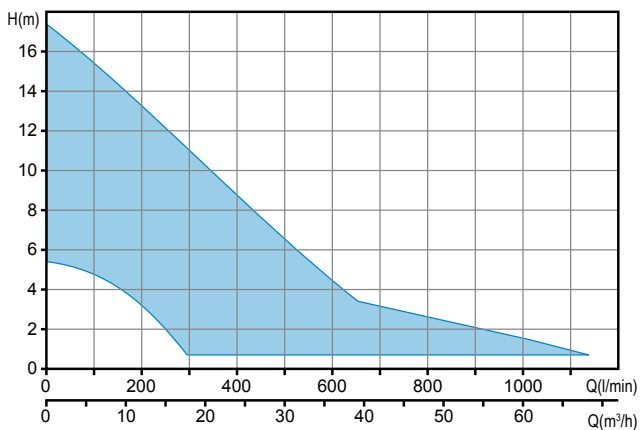

DRO

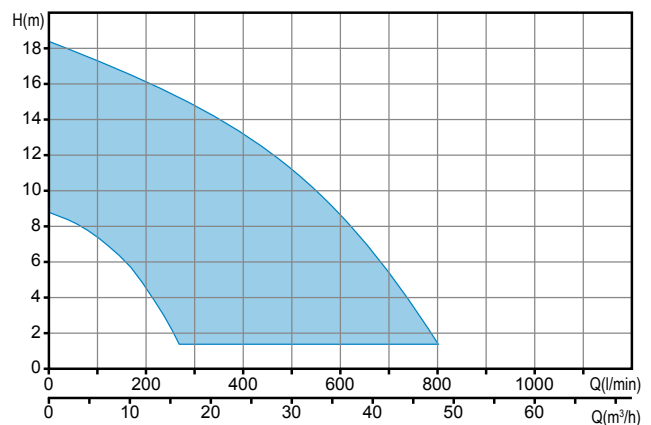

Versions available

• Electrical variants

Single-phase models

T	Thermal protection
TCST	Thermal protection, capacitor, electrical cabinet, overload protection
TCSGT	Thermal protection, capacitor, float switch, electrical cabinet, overload protection

Three-phase models

NAE	No electric accessories installed
------------	-----------------------------------

• Cooling system

N	No cooling and/or seal flushing system
----------	--

• Set of mechanical seals

SICAL	1 mechanical seal in silicon carbide and 1 mechanical seal in alumina graphite (NBR)
--------------	--

Key to product code

DRO 50/2/G32V A0BM5

① ② ③ (A) (B) (C) ④ ⑤ ⑥ ⑦ ⑧ ⑨

① Family	⑤ Hydraulic model
② Series	⑥ Version number
③ Power (HPx100) / motor poles	⑦ Motor size
④ Delivery rate	⑧ Motor phases
(A) TYPE (GAS thread/Flanged)	M = Single-phase
(B) DIAMETER (mm)	T = Three-phase
(C) POSITION	⑨ Power supply voltage frequency
V = vertical	5 = 50Hz
H = horizontal	6 = 60Hz

Installations

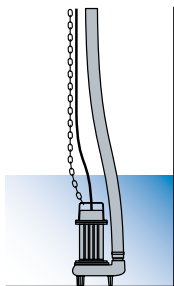

Free installation

The electric pump, standing on its feet or base, is connected to the delivery flexible pipe using a joint fixed to the discharge.

This installation allows to move easily the electrical pump

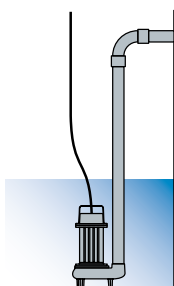

Fixed installation

The electric pump, standing on its feet or base, is connected to the delivery pipe, which is screwed to the discharge if threaded, or fixed to a bend if the port is flanged. The pump-hose connection may be threaded or flanged, depending on the pump fitting.

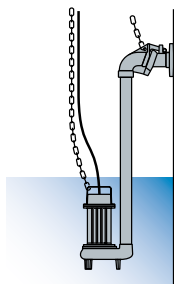

Installation with external coupler

Available for electric pumps with threaded discharge. The pump unit is supported by a special device fitted to the delivery pipe. This device can be installed at any time without having to empty the tank. It simplifies any maintenance work on the pump, which can be lifted out and resubmerged with great ease. It is recommended in particular for installations of small size, and does not require the pump to be resting on the bottom of the tank.

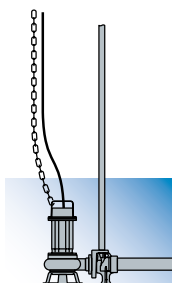
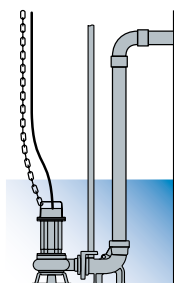

Installation with base coupling foot

For submerged installation, available for electric pumps with flanged or threaded horizontal discharge. The coupling device is fixed to the bottom of the tank and the pump is lowered in with the aid of two guide pipes fitted earlier, until the connection to the foot is completed. The delivery pipe is fixed to the coupling device discharge. This device makes routine checks, any maintenance work or replacement of the pump extremely easy, with no need to empty the tank. A specific kit also allowing pumps with vertical discharge to be installed with the base coupling foot is available.

Pumps with vortex impeller

Operating ranges

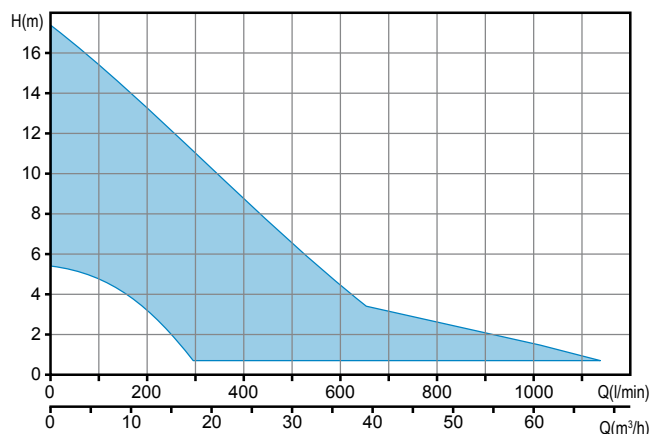

Range characteristics

Motor power	0.37 ÷ 1.5 kW
Poles	2 / 4
Insulation class	F
Degree of protection	IP68
Discharge	GAS 1½ ÷ 2½ vertical GAS 2" DN50 horizontal DN65 DN80 horizontal
Free passage	max 80 mm
Max flow rate	19.0 l/s (1140 l/min)
Max head	17.3 m

Motor

Oil bath motor with thermal protections.

Cable

H07RN-F - 5 m cable length. Optional 10 m cable length.

Mechanical seals

One silicon carbide mechanical seal (SiC) and one carbon-aluminium oxide mechanical seal (AL)

Applications

Suitable for heavy-duty applications with soiled biological wastewaters, sewage, rainwater and seepage.

Installations

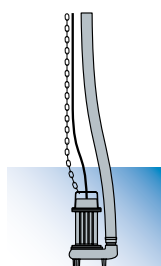

FREE

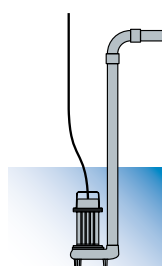

FIXED

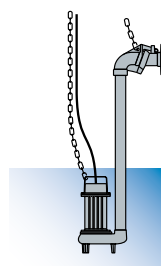

with EXTERNAL COUPLER

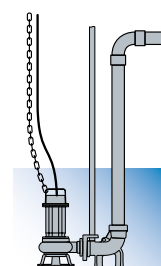

with BASE COUPLING FOOT

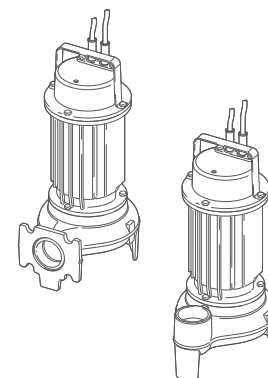
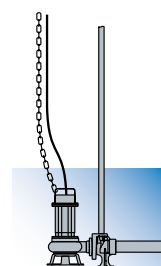

Versions

Electrical variants	T, TCST, TCSGT (single-phase models) NAE (three-phase models)
Cooling system	N
Mechanical seals	SICAL

Operating specifications

Max operating temperature	40 °C
PH of treated fluid	6 ÷ 14
Viscosity of treated fluid	1 mm²/s
Maximum immersion depth	3 m (cable length 5m) 7 m (cable length 10m)
Density of treated fluid	1 Kg/dm³
Acoustic pressure max	<70dB
Max starts per hour	30

Construction materials

Case	Cast iron EN-GJL 250
Hydraulic parts	Cast iron EN-GJL 250
Impeller	Cast iron EN-GJL 250
Nuts and bolts	Stainless steel - Class A2-70
Standard gasket	Rubber - NBR
Shaft	Stainless steel - AISI 431
Paint type	Ecological bicomponent epoxy (~ 120 µm)

DGO 2/G40V

Performances

	l/s	0	2	4	6	8
	l/min	0	120	240	360	480
	m³/h	0	7.2	14.4	21.6	28.8
① DGO 100/2/G40V B1CM(T)5		13.6	11.2	7.9	3.5	
② DGO 150/2/G40V B1CM(T)5		16.0	13.3	10	5.9	
③ DGO 200/2/G40V B1CM(T)5		17.3	14.7	11.6	7.8	2.8

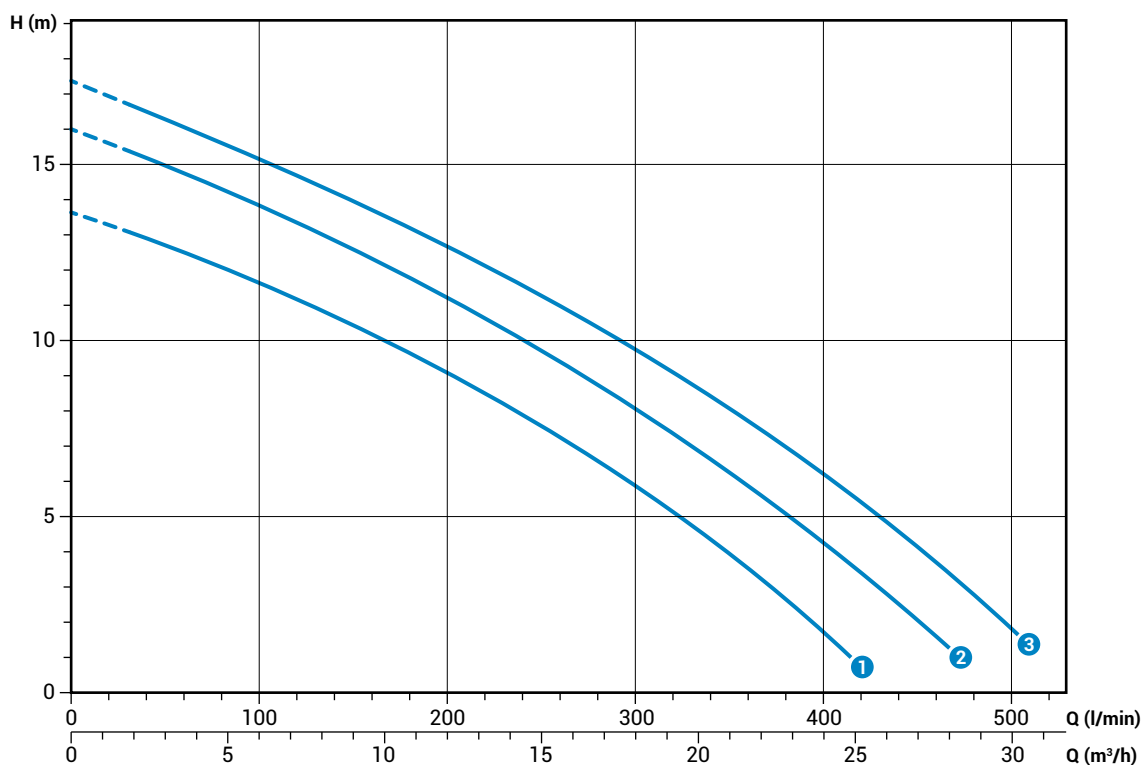

Characteristic curves according to UNI/EN ISO 9906

Technical data

	V	Phases	P1 (kW)	P2 (kW)	A	Rpm	Start	Cable	Ø	Free passage
① DGO 100/2/G40V B1CM5	230	1	-	0.88	6.4	2900	Dir	4G1	G 1½"	40 mm
② DGO 150/2/G40V B1CM5	230	1	-	1.1	8.3	2900	Dir	4G1	G 1½"	40 mm
③ DGO 200/2/G40V B1CM5	230	1	-	1.5	9.6	2900	Dir	4G1	G 1½"	40 mm

	V	Phases	P1 (kW)	P2 (kW)	A	Rpm	Start	Cable	Ø	Free passage
① DGO 100/2/G40V B1CT5	400	3	-	0.88	2.3	2900	Dir	4G1	G 1½"	40 mm
② DGO 150/2/G40V B1CT5	400	3	-	1.1	2.7	2900	Dir	4G1	G 1½"	40 mm
③ DGO 200/2/G40V B1CT5	400	3	-	1.5	3.6	2900	Dir	4G1	G 1½"	40 mm

DGO 2/G50V**Performances**

	l/s	0	2	4	6	8	10.0
	l/min	0	120	240	360	480	600
	m ³ /h	0	7.2	14.4	21.6	28.8	36.0
① DGO 50/2/G50V B0CM(T)5		6.0	4.5	2.3			
② DGO 75/2/G50V B0CM(T)5		8.6	7.2	5.1	2.3		
③ DGO 100/2/G50V B0CM(T)5		12.2	10.1	7.9	5.8	3.6	
④ DGO 150/2/G50V B0CM(T)5		14.2	11.8	9.5	7.3	5.1	2.7
⑤ DGO 200/2/G50V B0CM(T)5		15.8	13.6	11.2	8.9	6.6	4.4

Characteristic curves according to UNI/EN ISO 9906

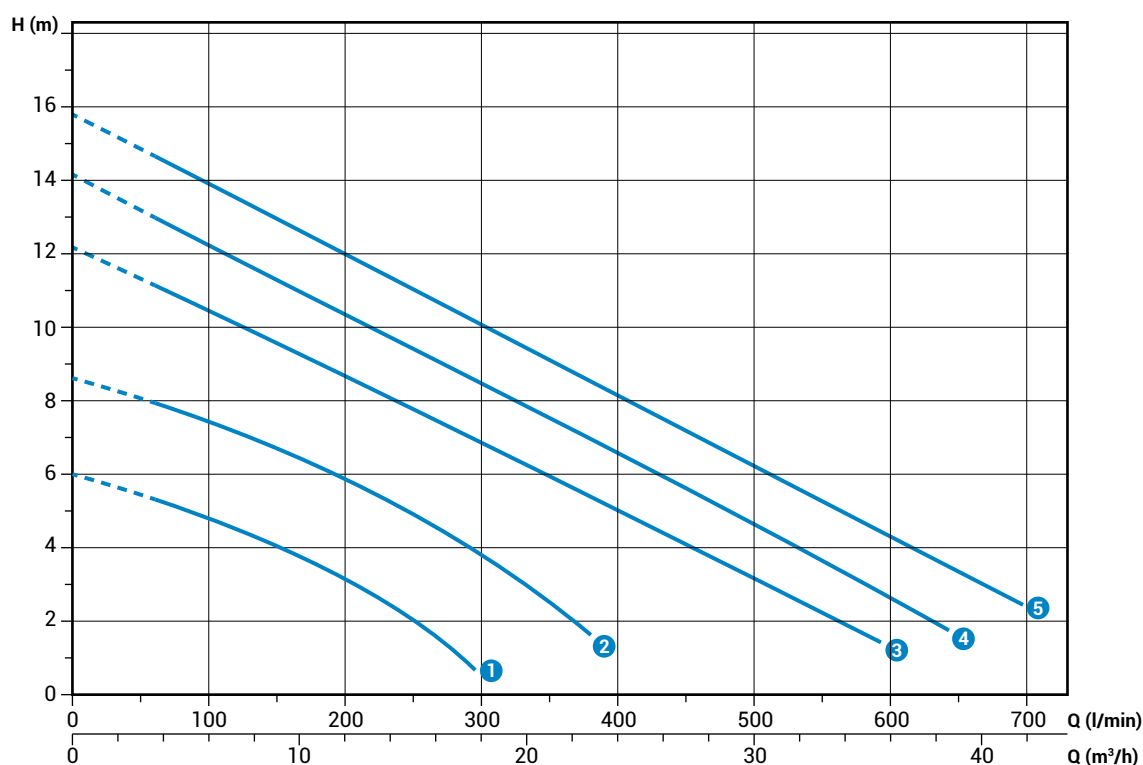
**Technical data**

	V	Phases	P1 (kW)	P2 (kW)	A	Rpm	Start	Cable	Ø	Free passage
① DGO 50/2/G50V B0CM5	230	1	-	0.37	2.9	2900	Dir	4G1	G 2"	40 mm
② DGO 75/2/G50V B0CM5	230	1	-	0.55	3.9	2900	Dir	4G1	G 2"	40 mm
③ DGO 100/2/G50V B0CM5	230	1	-	0.88	6.9	2900	Dir	4G1	G 2"	50 mm
④ DGO 150/2/G50V B0CM5	230	1	-	1.1	8.7	2900	Dir	4G1	G 2"	50 mm
⑤ DGO 200/2/G50V B0CM5	230	1	-	1.5	10.0	2900	Dir	4G1	G 2"	50 mm

	V	Phases	P1 (kW)	P2 (kW)	A	Rpm	Start	Cable	Ø	Free passage
① DGO 50/2/G50V B0CT5	400	3	-	0.37	1.1	2900	Dir	4G1	G 2"	40 mm
② DGO 75/2/G50V B0CT5	400	3	-	0.55	1.4	2900	Dir	4G1	G 2"	40 mm
③ DGO 100/2/G50V B0CT5	400	3	-	0.88	2.3	2900	Dir	4G1	G 2"	50 mm
④ DGO 150/2/G50V B0CT5	400	3	-	1.1	2.7	2900	Dir	4G1	G 2"	50 mm
⑤ DGO 200/2/G50V B0CT5	400	3	-	1.5	3.6	2900	Dir	4G1	G 2"	50 mm

DGO 2/G50H

Performances

	l/s	0	2	4	6	8	10
	l/min	0	120	240	360	480	600
	m ³ /h	0	7.2	14.4	21.6	28.8	36.0
① DGO 50/2/G50H A1CM(T)5		7.8	5.6	3.3	1.0		
② DGO 75/2/G50H A1CM(T)5		9.0	6.9	4.7	2.6		
③ DGO 100/2/G50H A0CM(T)5		12.7	10.6	8.2	5.7	3.1	
④ DGO 150/2/G50H A0CM(T)5		14.4	12.1	9.7	7.3	4.8	2.2
⑤ DGO 200/2/G50H A0CM(T)5		15.3	13.0	10.6	8.2	5.6	3.0

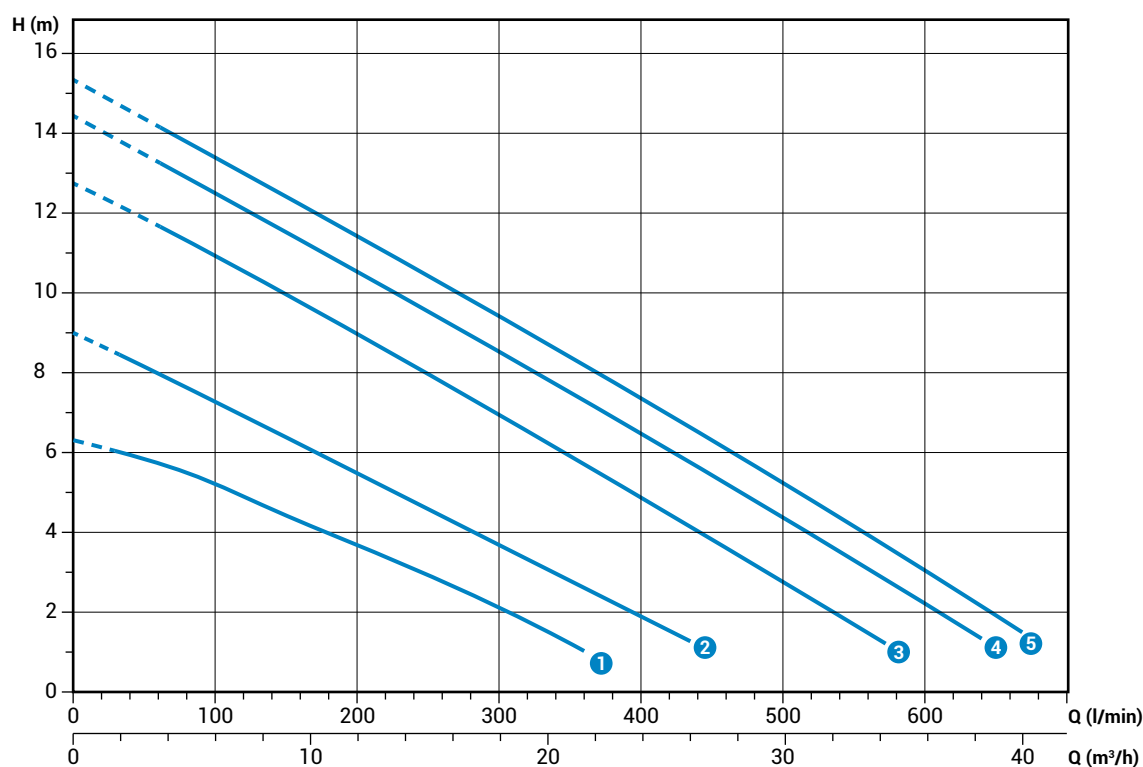

Characteristic curves according to UNI/EN ISO 9906

Technical data

	V	Phases	P1 (kW)	P2 (kW)	A	Rpm	Start	Cable	Ø	Free passage
① DGO 50/2/G50H A1CM5	230	1	-	0.37	2.9	2900	Dir	4G1	G 2"- DN50	40 mm
② DGO 75/2/G50H A1CM5	230	1	-	0.55	3.9	2900	Dir	4G1	G 2"- DN50	40 mm
③ DGO 100/2/G50H A0CM5	230	1	-	0.88	6.5	2900	Dir	4G1	G 2"- DN50	50 mm
④ DGO 150/2/G50H A0CM5	230	1	-	1.1	8.2	2900	Dir	4G1	G 2"- DN50	50 mm
⑤ DGO 200/2/G50H A0CM5	230	1	-	1.5	9.3	2900	Dir	4G1	G 2"- DN50	50 mm

	V	Phases	P1 (kW)	P2 (kW)	A	Rpm	Start	Cable	Ø	Free passage
① DGO 50/2/G50H A1CT5	400	3	-	0.37	1.1	2900	Dir	4G1	G 2"- DN50	40 mm
② DGO 75/2/G50H A1CT5	400	3	-	0.55	1.4	2900	Dir	4G1	G 2"- DN50	40 mm
③ DGO 100/2/G50H A0CT5	400	3	-	0.88	2.3	2900	Dir	4G1	G 2"- DN50	50 mm
④ DGO 150/2/G50H A0CT5	400	3	-	1.1	2.6	2900	Dir	4G1	G 2"- DN50	50 mm
⑤ DGO 200/2/G50H A0CT5	400	3	-	1.5	3.6	2900	Dir	4G1	G 2"- DN50	50 mm

DGO 2/G65V

Performances

	l/s	0	2	4	6	8	10.0
	l/min	0	120	240	360	480	600
	m ³ /h	0	7.2	14.4	21.6	28.8	36.0
① DGO 150/2/G65V A1CM(T)5		8.0	7.2	6.1	4.7	3.0	
② DGO 200/2/G65V A1CM(T)5		9.7	8.8	7.7	6.3	4.7	3.0

Characteristic curves according to UNI/EN ISO 9906

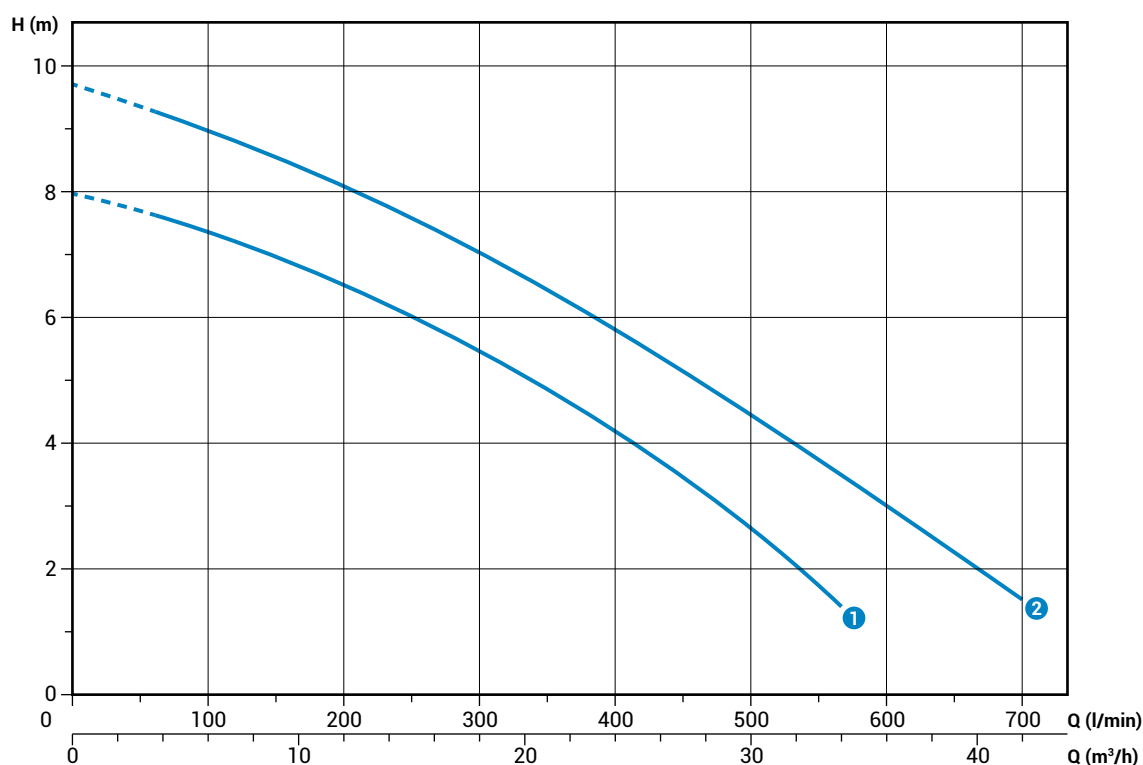

Technical data

	V	Phases	P1 (kW)	P2 (kW)	A	Rpm	Start	Cable	Ø	Free passage
① DGO 150/2/G65V A1CM5	230	1	-	1.1	8.2	2900	Dir	4G1	G 2½"	65 mm
② DGO 200/2/G65V A1CM5	230	1	-	1.5	10.0	2900	Dir	4G1	G 2½"	65 mm

	V	Phases	P1 (kW)	P2 (kW)	A	Rpm	Start	Cable	Ø	Free passage
① DGO 150/2/G65V A1CT5	400	3	-	1.1	2.7	2900	Dir	4G1	G 2½"	65 mm
② DGO 200/2/G65V A1CT5	400	3	-	1.5	3.6	2900	Dir	4G1	G 2½"	65 mm

DGO 2/65

Performances

	l/s	0	2	4	6	8	10	12	14
	l/min	0	120	240	360	480	600	720	840
	m ³ /h	0	7.2	14.4	21.6	28.8	36	43.2	50.4
①	DGO 150/2/65 A1CM(T)5	7.9	7.0	5.9	4.8	3.5	2.3		
②	DGO 200/2/65 A1CM(T)5	9.9	9.4	8.8	7.9	6.9	5.6	4.2	2.5

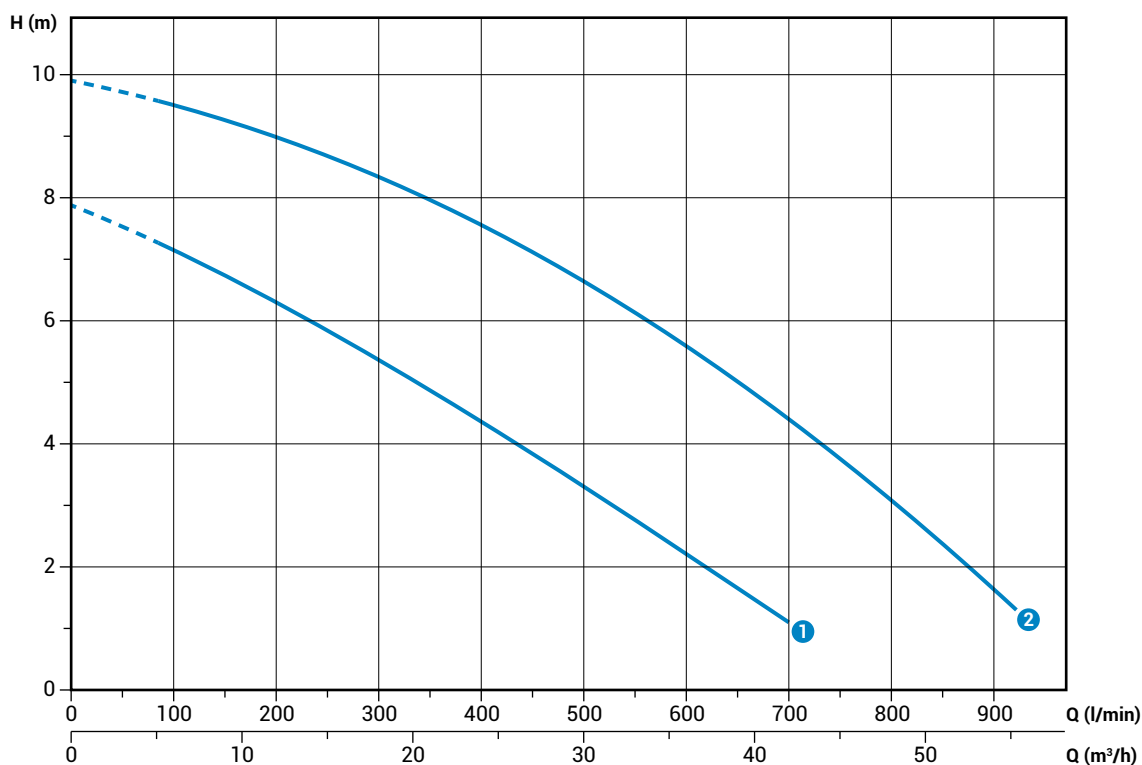

Characteristic curves according to UNI/EN ISO 9906

Technical data

	V	Phases	P1 (kW)	P2 (kW)	A	Rpm	Start	Cable	Ø	Free passage	
①	DGO 150/2/65 A1CM5	230	1	-	1.1	8.2	2900	Dir	4G1	DN65	65 mm
②	DGO 200/2/65 A1CM5	230	1	-	1.5	10.0	2900	Dir	4G1	DN65	65 mm

	V	Phases	P1 (kW)	P2 (kW)	A	Rpm	Start	Cable	Ø	Free passage	
①	DGO 150/2/65 A1CT5	400	3	-	1.1	2.7	2900	Dir	4G1	DN65	65 mm
②	DGO 200/2/65 A1CM5	400	3	-	1.5	3.6	2900	Dir	4G1	DN65	65 mm

DGO 2/80

Performances

	0	2	4	6	8	10	12	14	16
l/s	0	2	4	6	8	10	12	14	16
l/min	0	120	240	360	480	600	720	840	960
m ³ /h	0	7.2	14.4	21.6	28.8	36	43.2	50.4	57.6
① DGO 200/2/80 A1CM(T)5	8.4	7.9	7.2	6.4	5.5	4.5	3.6	2.6	1.7

Characteristic curves according to UNI/EN ISO 9906

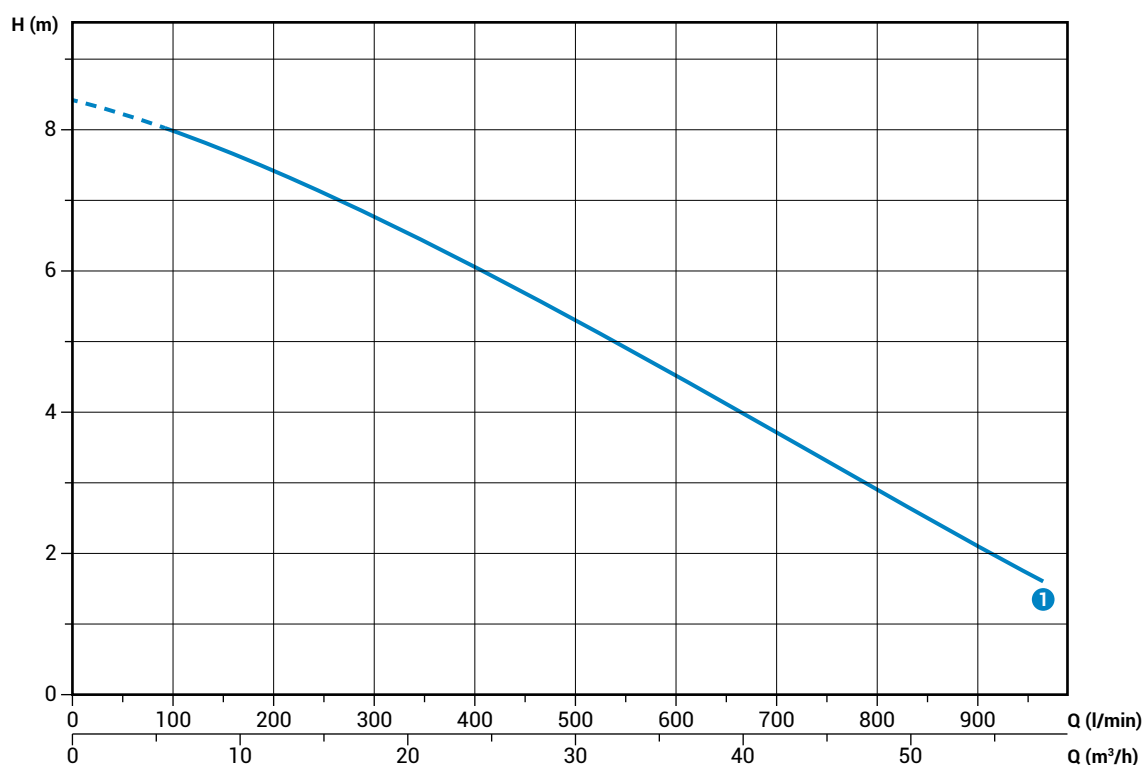

Technical data

	V	Phases	P1 (kW)	P2 (kW)	A	Rpm	Start	Cable	Ø	Free passage
① DGO 200/2/80 A1CM5 (*)	230	1	-	1.7	11.2	2900	Dir	4G1	DN80	80 mm

(*) TC and TCST versions only

	V	Phases	P1 (kW)	P2 (kW)	A	Rpm	Start	Cable	Ø	Free passage
① DGO 200/2/80 A1CT5	400	3	-	1.7	3.9	2900	Dir	4G1	DN80	80 mm

DGO 4/G50V

Performances

	l/s	0	2	4	6	8
	l/min	0	120	240	360	480
	m ³ /h	0	7.2	14.4	21.6	28.8
① DGO 100/4/G50V B0CM(T)5		5.4	4.8	4.0	3.0	1.8

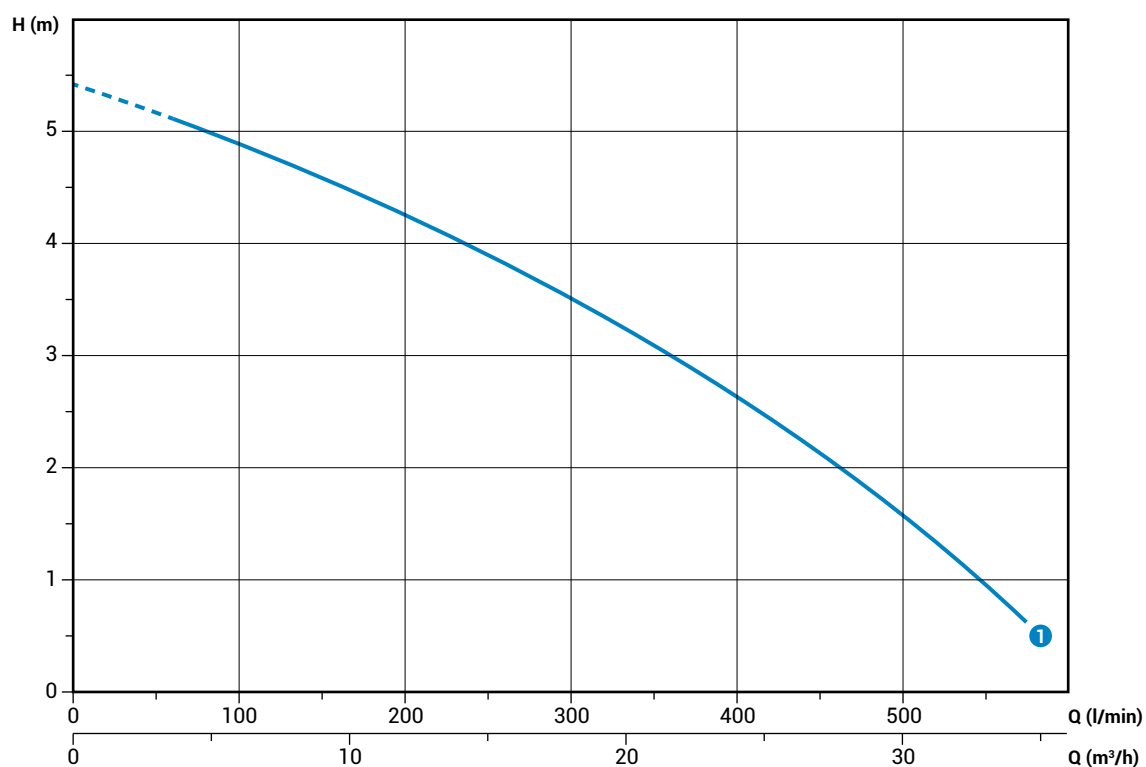

Characteristic curves according to UNI EN ISO 9906

Technical data

	V	Phases	P1 (kW)	P2 (kW)	A	Rpm	Start	Cable	Ø	Free passage
① DGO 100/4/G50V B0CM5	230	1	-	0.7	4.5	1450	Dir	4G1	G2"	45 mm

	V	Phases	P1 (kW)	P2 (kW)	A	Rpm	Start	Cable	Ø	Free passage
① DGO 100/4/G50V B0CT5	400	3	-	0.7	1.6	1450	Dir	4G1	G2"	45 mm

DGO 4/G50H

Performances

	l/s	0	2	4	6	8	10	12	14	16
	l/min	0	120	240	360	480	600	720	840	960
	m ³ /h	0	7.2	14.4	21.6	28.8	36	43.2	50.4	57.6
① DGO 100/4/G50H A0CM(T)5		8.4	7.9	7.2	6.4	5.5	4.5	3.6	2.6	1.7

Characteristic curves according to UNI/EN ISO 9906

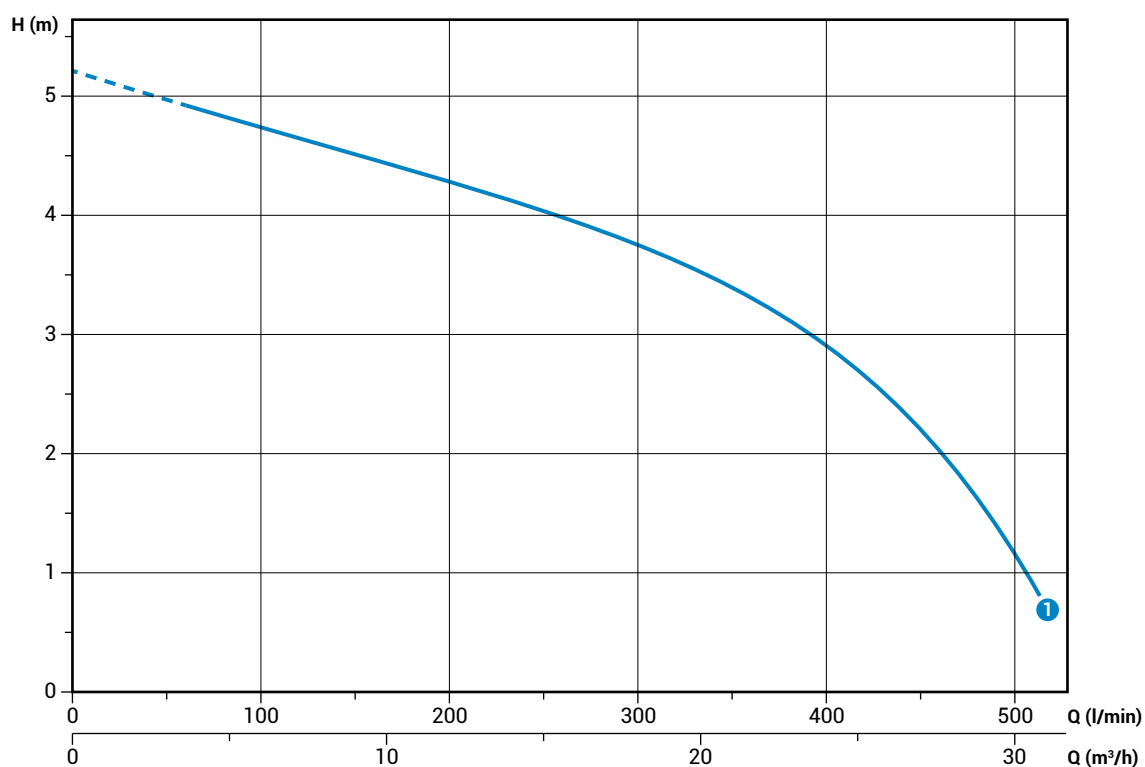

Technical data

	V	Phases	P1 (kW)	P2 (kW)	A	Rpm	Start	Cable	Ø	Free passage
① DGO 100/4/G50H A0CM5	230	1	-	0.7	5.7	1450	Dir	4G1	G2"-DN50	45 mm

	V	Phases	P1 (kW)	P2 (kW)	A	Rpm	Start	Cable	Ø	Free passage
① DGO 100/4/G50H A0CT5	400	3	-	0.7	2.2	1450	Dir	4G1	G2"-DN50	45 mm

DGO 4/65

Performances

	0	2	4	6	8	10	12
l/s	0	2	4	6	8	10	12
l/min	0	120	240	360	480	600	720
m ³ /h	0	7.2	14.4	21.6	28.8	36	43.2
① DGO 150/4/65 A0CM(T)5	5.9	5.5	5.1	4.6	3.9	3.0	1.9

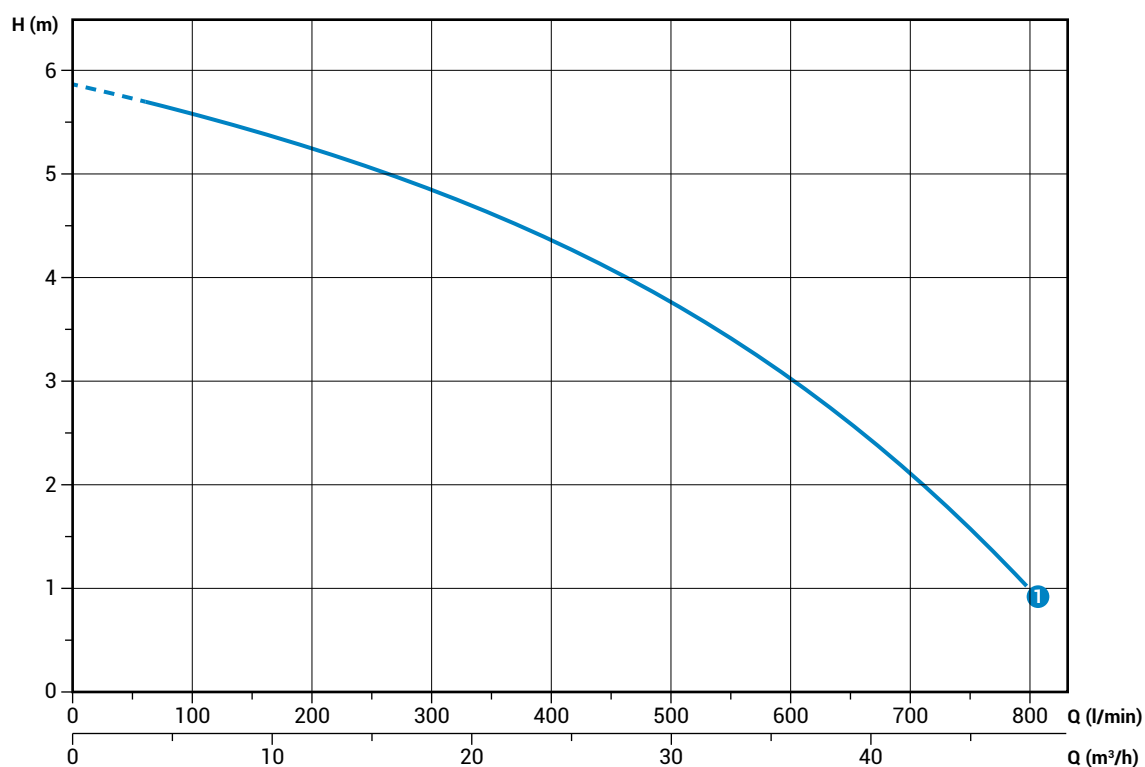

Characteristic curves according to UNI/EN ISO 9906

Technical data

	V	Phases	P1 (kW)	P2 (kW)	A	Rpm	Start	Cable	Ø	Free passage
① DGO 150/4/65 A0CM5	230	1	-	0.9	7.5	1450	Dir	4G1	DN65	45 mm

	V	Phases	P1 (kW)	P2 (kW)	A	Rpm	Start	Cable	Ø	Free passage
① DGO 150/4/65 A0CT5	400	3	-	0.9	2.8	1450	Dir	4G1	DN65	45 mm

Performances

	l/s	0	2	4	6	8	10	12	14	16	18
	l/min	0	120	240	360	480	600	720	840	960	1080
	m ³ /h	0	7.2	14.4	21.6	28.8	36	43.2	50.4	57.6	64.8
① DGO 150/4/80 A0CM(T)5		5.4	5.1	4.7	4.3	3.8	3.4	2.8	2.3	1.7	1.1

Characteristic curves according to UNI/EN ISO 9906

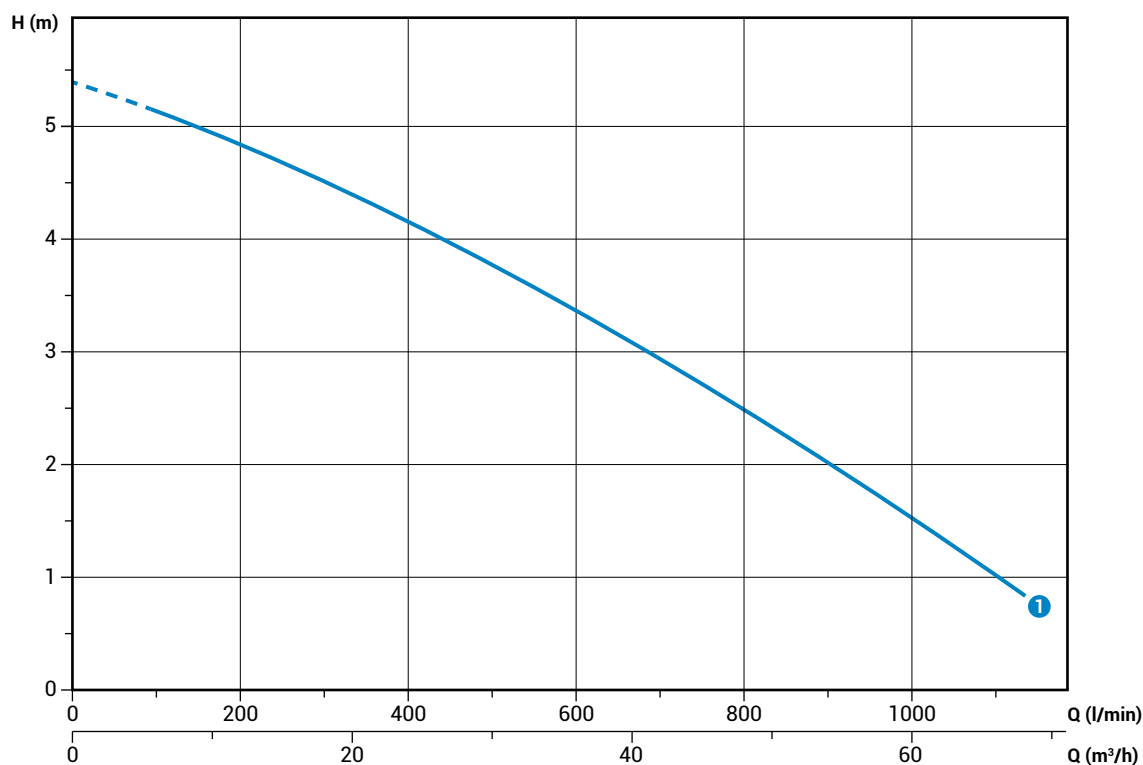

Technical data

	V	Phases	P1 (kW)	P2 (kW)	A	Rpm	Start	Cable	Ø	Free passage
① DGO 150/4/80 A0CM5	230	1	-	0.9	7.5	1450	Dir	4G1	DN80	60 mm

	V	Phases	P1 (kW)	P2 (kW)	A	Rpm	Start	Cable	Ø	Free passage
① DGO 150/4/80 A0CT5	400	3	-	0.9	2.8	1450	Dir	4G1	DN80	60 mm

DGO

Overall dimensions and weights

Models with vertical discharge

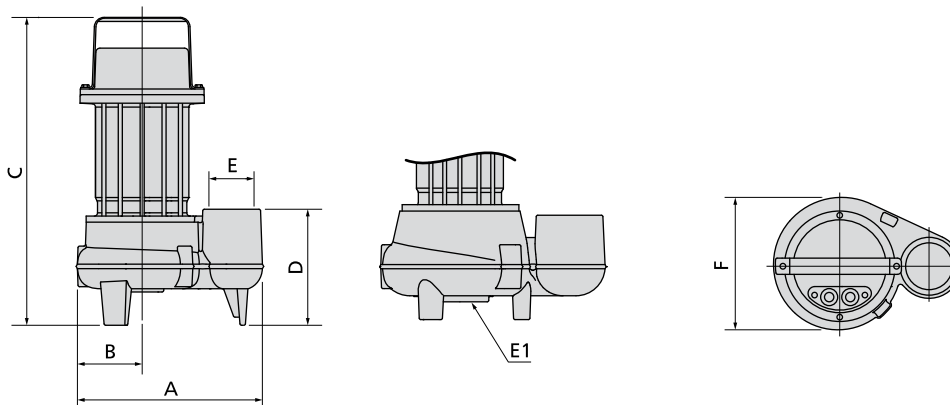

	A	B	C	D	E	E1	F	kg
DGO 100/2/G40V B1CM(T)5	260	100	440	125	G 1½"	-	205	18
DGO 150/2/G40V B10CM(T)5	260	100	440	125	G 1½"	-	205	19
DGO 200/2/G40V B1CM(T)5	260	100	440	125	G 1½"	-	205	20
DGO 50/2/G50V B0CM(T)5	230	80	380	120	G 2"	-	165	16.5
DGO 75/2/G50V B0CM(T)5	230	80	380	120	G 2"	-	165	16.5
DGO 100/2/G50V B0CM(T)5	270	100	455	130	G 2"	-	205	19.5
DGO 150/2/G50V B0CM(T)5	270	100	455	130	G 2"	-	205	20.5
DGO 200/2/G50V B0CM(T)5	270	100	455	130	G 2"	-	205	21.5
DGO 150/2/G65V A1CM(T)5	300	105	435	140	G 2½"	3xM8 Ø160	210	21
DGO 200/2/G65V A1CM(T)5	300	105	435	140	G 2½"	3xM8 Ø160	210	22
DGO 100/4/G50V B0CM(T)5	270	100	455	130	G 2"	-	205	21

Dimensions in mm

Models with horizontal discharge

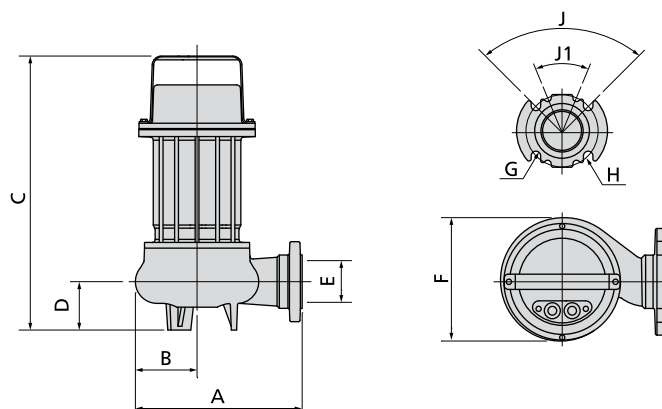

	A	B	C	D	E	F	G	H	J	J1	kg
DGO 50/2/G50H A1CM(T)5	220	80	360	65	G 2" - DN50	160	18	125	90°	-	16.5
DGO 75/2/G50H A1CM(T)5	220	80	360	65	G 2" - DN50	160	18	125	90°	-	16.5
DGO 100/2/G50H A0CM(T)5	270	110	455	110	G 2" - DN50	205	18	125	90°	-	19.5
DGO 150/2/G50H A0CM(T)5	270	110	455	110	G 2" - DN50	205	18	125	90°	-	20.5
DGO 200/2/G50H A0CM(T)5	270	110	455	110	G 2" - DN50	205	18	125	90°	-	21.5
DGO 100/4/G50H A0CM(T)5	270	110	450	110	G 2" - DN50	205	18	125	90°	-	21

Dimensions in mm

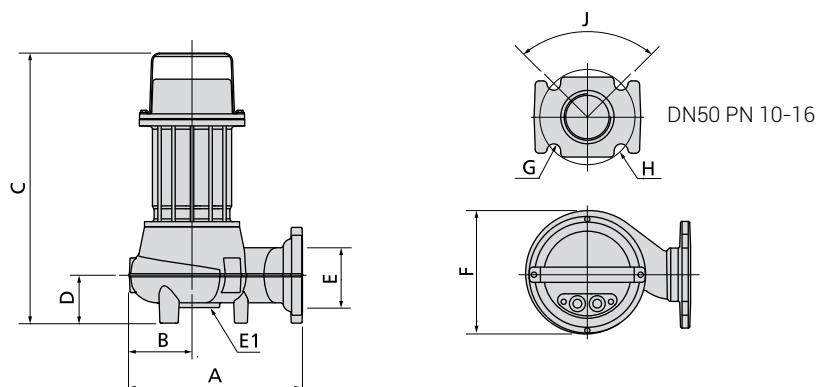

	A	B	C	D	E	E1	F	G	H	J	J1	kg
DGO 150/2/65 A1CM(T)5	295	110	435	70	65	3xM8 Ø160	210	18	145	90°	-	22
DGO 200/2/65 A1CM(T)5	295	110	435	70	65	3xM8 Ø160	210	18	145	90°	-	23
DGO 200/2/80 A1CM(T)5	290	105	450	80	80	3xM8 Ø160	210	18	160	90°	45°	23
DGO 150/4/65 A0CM(T)5	270	110	450	105	65	-	220	18	145	90°	-	27
DGO 150/4/80 A0CM(T)5	270	115	480	125	80	-	225	18	160	90°	-	29

Dimensions in mm

Packaging dimension



	X	Y	Z		X	Y	Z
DGO 100/2/G40V B1CM(T)5	285	475	235	DGO 150/2/G50H A0CM(T)5	285	475	235
DGO 150/2/G40V B1CM(T)5	285	475	235	DGO 200/2/G50H A0CM(T)5	285	475	235
DGO 200/2/G40V B1CM(T)5	285	475	235	DGO 150/2/G65V A1CM(T)5	285	475	235
DGO 50/2/G50V B0CM(T)5	225	385	245	DGO 200/2/G65V A1CM(T)5	285	475	235
DGO 75/2/G50V B0CM(T)5	225	385	245	DGO 150/2/65 A1CM(T)5	310	580	310
DGO 100/2/G50V B0CM(T)5	285	475	235	DGO 200/2/65 A1CM/(T)5	310	580	310
DGO 150/2/G50V B0CM(T)5	285	475	235	DGO 200/2/80 A1CM(T)5	310	580	310
DGO 200/2/G50V B0CM(T)5	285	475	235	DGO 100/4/G50V B0CM(T)5	285	475	235
DGO 50/2/G50H A1CM(T)5	225	385	245	DGO 100/4/G50H A0CM(T)5	285	475	235
DGO 75/2/G50H A1CM(T)5	225	385	245	DGO 150/4/65 A0CM(T)5	310	580	310
DGO 100/2/G50H A0CM(T)5	285	475	235	DGO 150/4/80 A0CM(T)5	310	580	310

Dimensions in mm

DRO

Pumps with multi-channel open impeller

Operating ranges

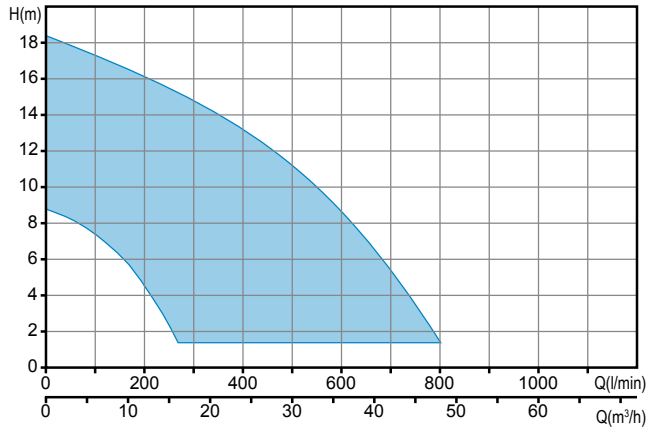

Range characteristics

Motor power	0.37 ÷ 1.5 kW
Poles	2
Insulation class	F
Degree of protection	IP68
Discharge	GAS 1¼ ÷ 2" vertical GAS 2" DN50 horizontal
Free passage	max 15 mm
Max flow rate	13.0 l/s (780 l/min)
Max head	18.4 m

Motor

Oil bath motor with thermal protections.

Cable

H07RN-F 4G1 - 5 m cable length. Optional 10 m cable length.

Mechanical seals

One silicon carbide mechanical seal (SiC) and one carbon-aluminium oxide mechanical seal (AL)

Applications

Can be used with clear or slightly soiled wastewaters containing small solids, strained water, rainwater, seepage and water pumped from underground.

Installations

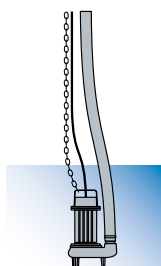

FREE

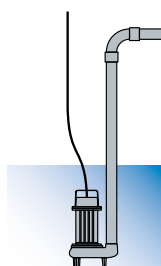

FIXED

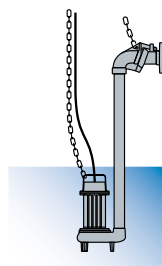

with EXTERNAL COUPLER

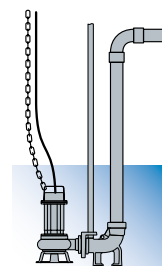

with BASE COUPLING FOOT

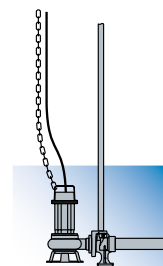

with BASE COUPLING FOOT

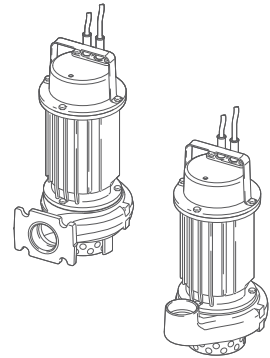

Versions

Electrical variants	T, TCST, TCSGT (single-phase models) NAE (three-phase models)
Cooling system	N
Mechanical seals	SICAL

Operating specifications

Max operating temperature	40 °C
PH of treated fluid	6 ÷ 14
Viscosity of treated fluid	1 mm²/s
Maximum immersion depth	3 m (cable length 5m) 7 m (cable length 10m)
Density of treated fluid	1 Kg/dm³
Acoustic pressure max	<70dB
Max starts per hour	30

Construction materials

Case	Cast iron EN-GJL 250
Hydraulic parts	Cast iron EN-GJL 250
Impeller	Cast iron EN-GJL 250
Nuts and bolts	Stainless steel - Class A2-70
Standard gasket	Rubber - NBR
Shaft	Stainless steel - AISI 431
Paint type	Ecological bicomponent epoxy (~ 120 µm)

DRO 2/G32V**Performances**

	l/s	0	1	2	3	4	5	6
	l/min	0	60	120	180	240	300	360
	m ³ /h	0	3.6	7.2	10.8	14.4	18.0	21.6
①	DRO 50/2/G32V A0CM(T)5	8.8	8.1	6.9	5.2	2.7		
②	DRO 75/2/G32V A0CM(T)5	12.1	11.8	10.8	9.1	6.9	4.2	0.9

Characteristic curves according to UNI/EN ISO 9906

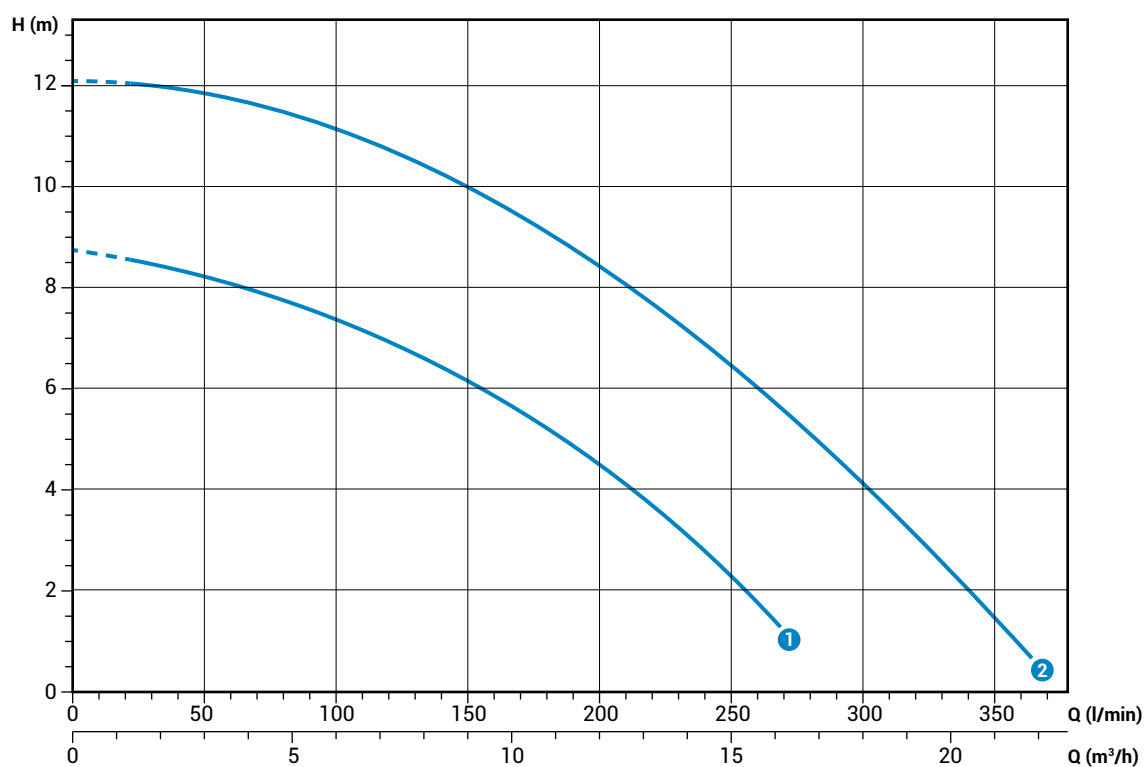
**Technical data**

	V	Phases	P1 (kW)	P2 (kW)	A	Rpm	Start	Cable	Ø	Free passage	
①	DRO 50/2/G32V A0CM5	230	1	-	0.37	2.9	2900	Dir	4G1	G 1¼"	15 mm
②	DRO 75/2/G32V A0CM5	230	1	-	0.55	3.9	2900	Dir	4G1	G 1¼"	15 mm

	V	Phases	P1 (kW)	P2 (kW)	A	Rpm	Start	Cable	Ø	Free passage	
①	DRO 50/2/G32V A0CT5	400	3	-	0.37	1.1	2900	Dir	4G1	G 1¼"	15 mm
②	DRO 75/2/G32V A0CT5	400	3	-	0.55	1.4	2900	Dir	4G1	G 1¼"	15 mm

DRO 2/G50V

Performances

	l/s	0	2	4	6	8	10	12
	l/min	0	120	240	360	480	600	720
	m ³ /h	0	7.2	14.4	21.6	28.8	36	43.2
① DRO 100/2/G50V A0CM(T)5		12.4	11.5	10.0	7.9	5.0	1.1	
② DRO 150/2/G50V A0CM(T)5		16.3	15.2	13.8	11.9	9.3	6.0	2.1
③ DRO 200/2/G50V A0CM(T)5		18.4	17.1	15.6	13.9	11.7	8.6	4.5

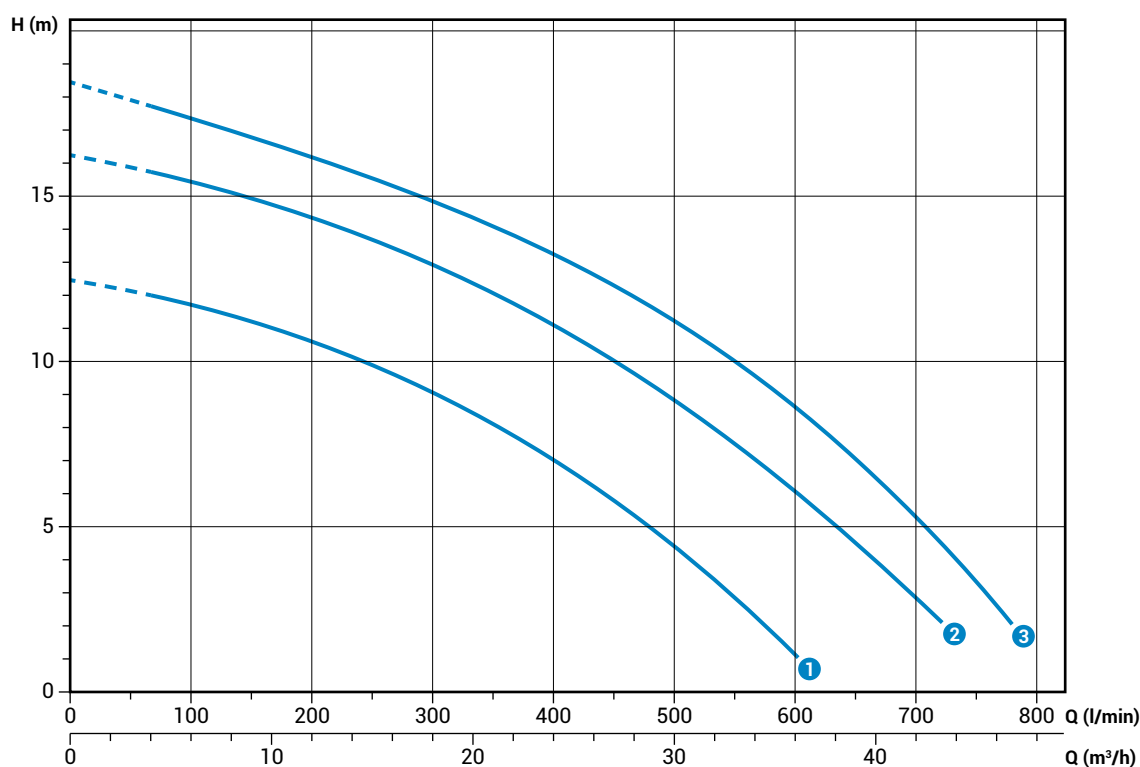

Characteristic curves according to UNI/EN ISO 9906

Technical data

	V	Phases	P1 (kW)	P2 (kW)	A	Rpm	Start	Cable	Ø	Free passage
① DRO 100/2/G50V A0CM5	230	1	-	0.88	6.5	2900	Dir	4G1	G 2"	15 mm
② DRO 150/2/G50V A0CM5	230	1	-	1.1	8.2	2900	Dir	4G1	G 2"	15 mm
③ DRO 200/2/G50V A0CM5	230	1	-	1.5	9.3	2900	Dir	4G1	G 2"	15 mm

	V	Phases	P1 (kW)	P2 (kW)	A	Rpm	Start	Cable	Ø	Free passage
① DRO 100/2/G50V A0CT5	400	3	-	0.88	2.3	2900	Dir	4G1	G 2"	15 mm
② DRO 150/2/G50V A0CT5	400	3	-	1.1	2.7	2900	Dir	4G1	G 2"	15 mm
③ DRO 200/2/G50V A0CT5	400	3	-	1.5	3.5	2900	Dir	4G1	G 2"	15 mm

DRO 2/G50H**Performances**

	I/s	0	2	4	6	8	10	12
	l/min	0	120	240	360	480	600	720
	m ³ /h	0	7.2	14.4	21.6	28.8	36	43.2
① DRO 100/2/G50H A0CM(T)5		12.4	11.5	10.0	7.9	5.0	1.1	
② DRO 150/2/G50H A0CM(T)5		16.3	15.2	13.8	11.9	9.3	6.0	2.1
③ DRO 200/2/G50H A0CM(T)5		18.4	17.1	15.6	13.9	11.7	8.6	4.5

Characteristic curves according to UNI/EN ISO 9906

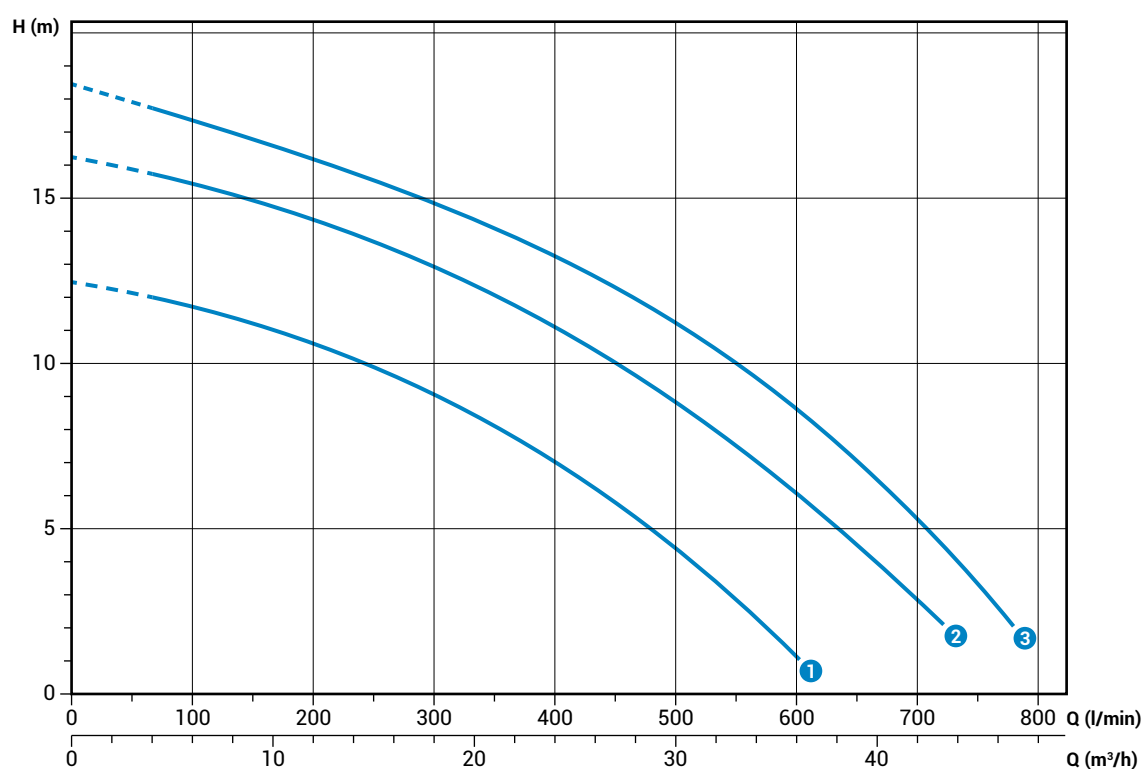
**Technical data**

	V	Phases	P1 (kW)	P2 (kW)	A	Rpm	Start	Cable	Ø	Free passage
① DRO 100/2/G50H A0CM5	230	1	-	0.88	6.5	2900	Dir	4G1	G 2"	15 mm
② DRO 150/2/G50H A0CM5	230	1	-	1.1	8.2	2900	Dir	4G1	G 2"	15 mm
③ DRO 200/2/G50H A0CM5	230	1	-	1.5	9.3	2900	Dir	4G1	G 2"	15 mm

	V	Phases	P1 (kW)	P2 (kW)	A	Rpm	Start	Cable	Ø	Free passage
① DRO 100/2/G50H A0CT5	400	3	-	0.88	2.3	2900	Dir	4G1	G 2"	15 mm
② DRO 150/2/G50H A0CT5	400	3	-	1.1	2.7	2900	Dir	4G1	G 2"	15 mm
③ DRO 200/2/G50H A0CT5	400	3	-	1.5	3.5	2900	Dir	4G1	G 2"	15 mm

DRO

Overall dimensions and weights

Models with vertical discharge

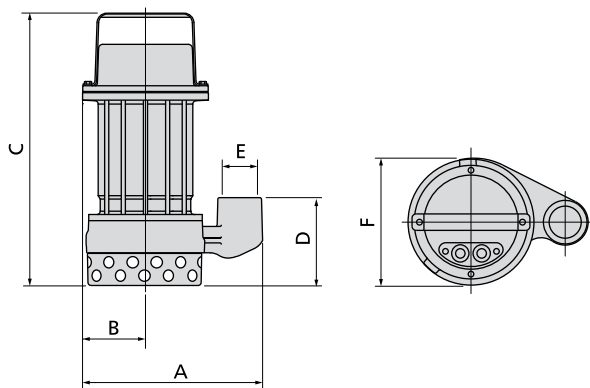

Models with horizontal discharge

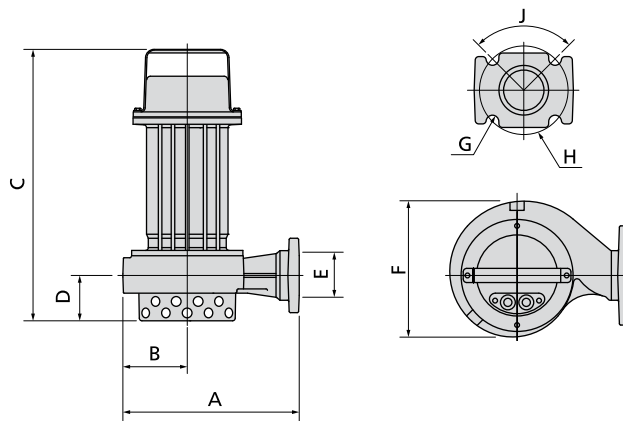

	A	B	C	D	E	F	kg
DRO 50/2/G32V A0CM(T)5	220	75	330	105	G 1 1/4"	155	15
DRO 75/2/G32V A0CM(T)5	220	75	330	105	G 1 1/4"	155	15.5
DRO 100/2/G50V A0CM(T)5	260	95	385	125	G 2"	195	19.5
DRO 150/2/G50V A0CM(T)5	260	95	385	125	G 2"	195	20.5
DRO 200/2/G50V A0CM(T)5	260	95	385	125	G 2"	195	21.5

Dimensions in mm

	A	B	C	D	E	F	G	H	J	kg
DRO 100/2/G50H A0CM(T)5	250	90	385	65	G 2"-DN50	195	18	125	90°	19.5
DRO 150/2/G50H A0CM(T)5	250	90	385	65	G 2"-DN50	195	18	125	90°	20.5
DRO 200/2/G50H A0CM(T)5	250	90	385	65	G 2"-DN50	195	18	125	90°	21.5

Dimensions in mm

Packaging dimension



	X	Y	C
DRO 50/2/G32V A0CM(T)5	225	385	245
DRO 75/2/G32V A0CM(T)5	225	385	245
DRO 100/2/G50V A0CM(T)5	285	475	235
DRO 150/2/G50V A0CM(T)5	285	475	235
DRO 200/2/G50V A0CM(T)5	285	475	235
DRO 100/2/G50H A0CM(T)5	285	475	235
DRO 150/2/G50H A0CM(T)5	285	475	235
DRO 200/2/G50H A0CM(T)5	285	475	235

Dimensions in mm

Hydraulic performance data

For quick, easy reference

DGO	I/s	0	2	4	6	8	10	12	14	16	18
	l/min	0	120	240	360	480	600	720	840	960	1080
	m ³ /h	0	7.2	14.4	21.6	28.8	36	43.2	50.4	57.6	64.8
DGO 100/2/G40V B1CM(T)5		13.6	11.2	7.9	3.5						
DGO 150/2/G40V B1CM(T)5		16.0	13.3	10.0	5.9						
DGO 200/2/G40V B1CM(T)5		17.3	14.7	11.6	7.8	2.8					
DGO 50/2/G50V B0CM(T)5		6.0	4.5	2.3							
DGO 75/2/G50V B0CM(T)5		8.6	7.2	5.1	2.3						
DGO 100/2/G50V B0CM(T)5		12.2	10.1	7.9	5.8	3.6					
DGO 150/2/G50V B0CM(T)5		14.2	11.8	9.5	7.3	5.1	2.7				
DGO 200/2/G50V B0CM(T)5		15.8	13.6	11.2	8.9	6.6	4.4				
DGO 50/2/G50H A1CM(T)5		7.8	5.6	3.3	1.0						
DGO 75/2/G50H A1CM(T)5		9.0	6.9	4.7	2.6						
DGO 100/2/G50H A0CM(T)5		12.7	10.6	8.2	5.7	3.1					
DGO 150/2/G50H A0CM(T)5		14.4	12.1	9.7	7.3	4.8	2.2				
DGO 200/2/G50H A0CM(T)5		15.3	13.0	10.6	8.2	5.6	3.0				
DGO 150/2/G65V A1CM(T)5		8.0	7.2	6.1	4.7	3.0					
DGO 200/2/G65V A1CM(T)5		9.7	8.8	7.7	6.3	4.7	3.0				
DGO 150/2/65 A1CM(T)5		7.9	7.0	5.9	4.8	3.5	2.3				
DGO 200/2/65 A1CM(T)5		9.9	9.4	8.8	7.9	6.9	5.6	4.2	2.5		
DGO 200/2/80 A1CM(T)5		8.4	7.9	7.2	6.4	5.5	4.5	3.6	2.6	1.7	
DGO 100/4/G50V B0CM(T)5		5.4	4.8	4.0	3.0	1.8					
DGO 100/4/G50H A0CM(T)5		5.2	4.7	4.1	3.3	1.6					
DGO 150/4/65 A0CM(T)5		5.9	5.5	5.1	4.6	3.9	3.0	1.9			
DGO 150/4/80 A0CM(T)5		5.4	5.1	4.7	4.3	3.8	3.4	2.8	2.3	1.7	1.1

DRO	I/s	0	2	4	6	8	10	12
	l/min	0	120	240	360	480	600	720
	m ³ /h	0	7.2	14.4	21.6	28.8	36	43.2
DRO 50/2/G32V A0CM(T)5		8.8	6.9	2.7				
DRO 75/2/G32V A0CM(T)5		12.1	10.8	6.9	0.9			
DRO 100/2/G50V A0CM(T)5		12.4	11.5	10.0	7.9	5.0	1.1	
DRO 150/2/G50V A0CM(T)5		16.3	15.2	13.8	11.9	9.3	6.0	2.1
DRO 200/2/G50V A0CM(T)5		18.4	17.1	15.6	13.9	11.7	8.6	4.5
DRO 50/2/G32H A0CM(T)5		8.8	6.9	2.7				
DRO 75/2/G32H A0CM(T)5		12.1	10.8	6.9	0.9			
DRO 100/2/G50H A0CM(T)5		12.4	11.5	10.0	7.9	5.0	1.1	
DRO 150/2/G50H A0CM(T)5		16.3	15.2	13.8	11.9	9.3	6.0	2.1
DRO 200/2/G50H A0CM(T)5		18.4	17.1	15.6	13.9	11.7	8.6	4.5



better together